

DC-DC Converters and Long Supply Cables

Author: Adrian Mills

Date: 7-11-05

Rev: 1.1

www.summitelectronics.co.uk

INTRODUCTION

Powering low voltage equipment located a relatively long distance from its power source requires some careful design considerations when employing DC-DC converters. The large source resistance presented by the long line will almost certainly cause the converters input to become bistable. The goal of this article is to provide tools to evaluate power supply requirements for a set of conditions and a method to avoid bistable operation.

WHY USE A DC-DC CONVERTER

When powering low voltage equipment over a long power line with a large source resistance (R_S), it's desirable to deliver the power as efficiently as possible. Greater efficiency permits the equipment to be either located further away (over a longer line) or have more power made available to it. The DC-DC offers high efficiency when compared to a linear regulator. Further, should the equipment be positioned close to the power source on a short line, the power required to be dissipated in the form of heat by a linear regulator may demand an intolerably large heat sink. One might argue that tailoring the supply voltage for a given installation would provide a solution but this is undesirable when a number of units are powered from the same source. Alternatively we might use heavier gauge copper but this may not always be possible due to cost, or if the equipment has to use existing cabling.

POWER SUPPLY SYSTEM

Figure 1 shows the arrangement of our power supply. R_S represents the loop source resistance of the supply cable. So for example, a cable with a resistance of 0.04Ω per meter will have a loop resistance twice this since two conductors are required to deliver power. If this were a 500m cable then R_S would be $2 \times 500 \times 0.04 = 40\Omega$.

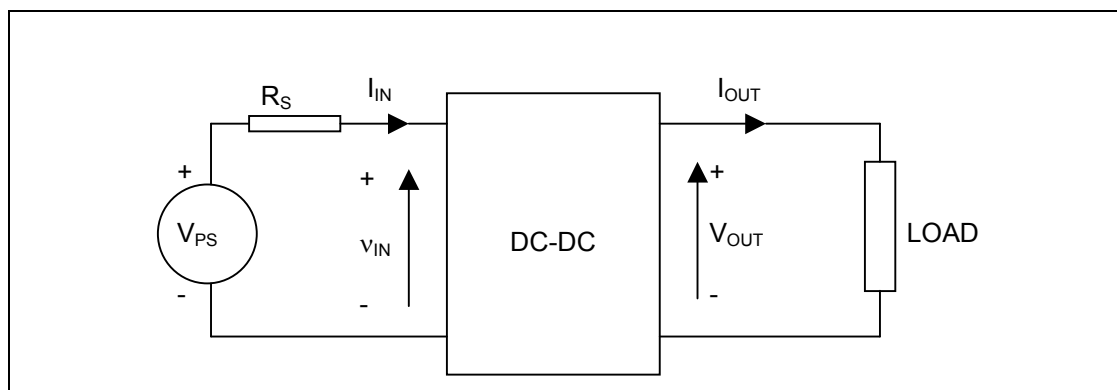

Figure 1 POWER SUPPLY SYSTEM

From Figure 1 we deduce equations for,

Power delivered to the load:

$$P_{OUT} = I_{OUT} V_{OUT} \quad (1)$$

Power input to the DC-DC:

$$P_{IN} = P_{OUT} / \eta_{DC} \quad (2)$$

Where: η_{DC} is the efficiency of the DC-DC converter

Power supply power:

$$P_{PS} = I_{IN} V_{PS} \quad (3)$$

I_{IN} in terms of V_{PS} , R_S & v_{IN} (load line):

$$I_{IN} = \frac{V_{PS} - v_{IN}}{R_S} \quad (4)$$

I_{IN} in terms of P_{IN} and v_{IN} (DC-DC I-V curve):

$$I_{IN} = \frac{P_{IN}}{v_{IN}} \quad (5a)$$

Solving I_{IN} from equations (2) and (5a):

$$I_{IN} = \frac{P_{OUT}}{v_{IN} \eta_{DC}} \quad (5b)$$

The question that arises from Figure 1 is:

What supply voltage (V_{PS}) and current is required for a given load power (P_{OUT}) and cabling resistance (R_S)?

Before we can answer this question, we need to look at the input characteristics of the DC-DC and do some load line analysis.

DC-DC CONVERTER: PERFECT CHARACTERISTICS

Figure 2 shows the perfect characteristics of a DC-DC converter. As v_{IN} tends to zero I_{IN} tends to infinity and as v_{IN} tends to infinity I_{IN} tends to zero. A real DC-DC converter is not like this but we'll use the characteristic as a starting place for our analysis.

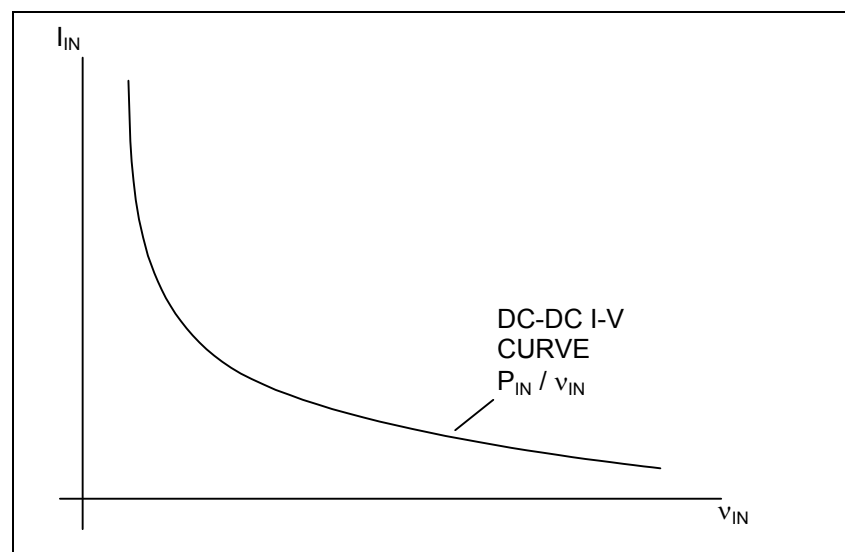

Figure 2 INPUT CHARACTERISTICS OF A PERFECT DC-DC CONVERTER

Lets now superimpose the load line characteristics of the power line with that of the DC-DC input characteristics. See Figure 3.

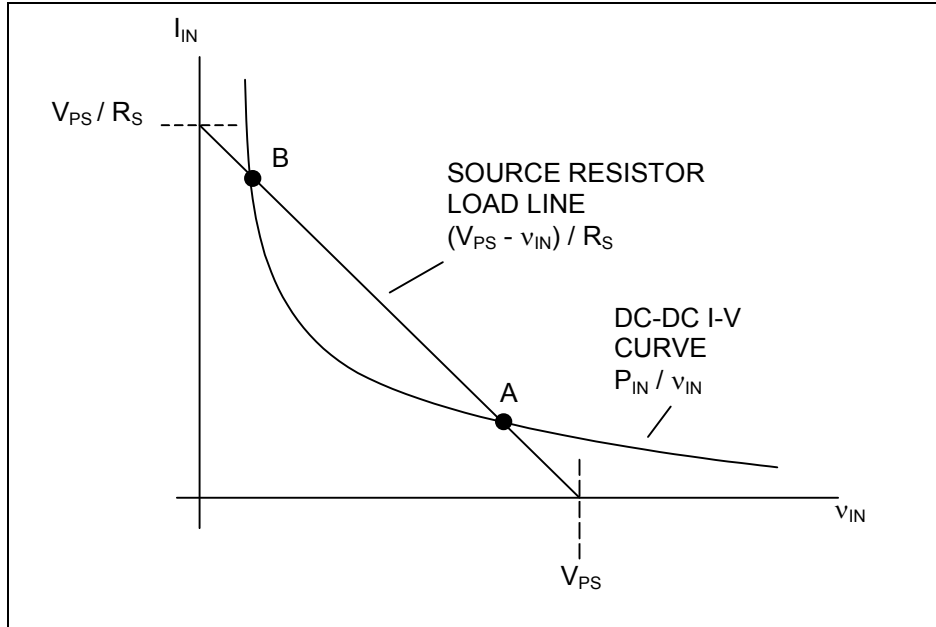

Figure 3 BISTABLE LOAD LINE

From Figure 3 we see that the DC-DC converter can operate in either state A or state B, this is known as bistable operation [1] and is normally avoided by designing it out of the system. In this example, operation in state B is undesirable, as it requires a higher I_{IN} and therefore power from the supply. Further v_{IN} may be so low that the DC-DC is unable to operate! Although not the full story, this is the main reason why bistable operation is avoided.

Equating (4) and (5b) and solving v_{IN} yields a quadratic for which the solution is:

$$v_{IN} = \frac{V_{PS} \pm \sqrt{V_{PS}^2 - \frac{4 R_S P_{OUT}}{\eta_{DC}}}}{2} \quad (6)$$

Hence v_{IN} for state A is:

$$v_{INA} = \frac{V_{PS} + \sqrt{V_{PS}^2 - \frac{4 R_S P_{OUT}}{\eta_{DC}}}}{2} \quad (7)$$

and v_{IN} for state B is:

$$V_{INB} = \frac{V_{PS} - \sqrt{V_{PS}^2 - \frac{4 R_S P_{OUT}}{\eta_{DC}}}}{2} \quad (8)$$

Let's now increase the power required by the load so that the curve represented by P_{IN} / v_{IN} just intersects the load line at AB as shown in Figure 4.

In this case, the term $\sqrt{V_{PS}^2 - \frac{4 R_S P_{OUT}}{\eta_{DC}}}$ in (6) becomes zero.

thus:

$$V_{PS}^2 - \frac{4 R_S P_{OUT}}{\eta_{DC}} = 0 \quad (9)$$

We can also define v_{IN} for state AB, let's call it V_{AB} , from (6) by simply omitting the zero term above:

$$V_{AB} = \frac{V_{PS}}{2} \quad (10)$$

This represents the limit of operation. In other words, this is the maximum power (P_{OUT}) the load may consume or this is the maximum the source resistance (R_S , and hence cable length) can be, before the DC-DC converter fails to operate.

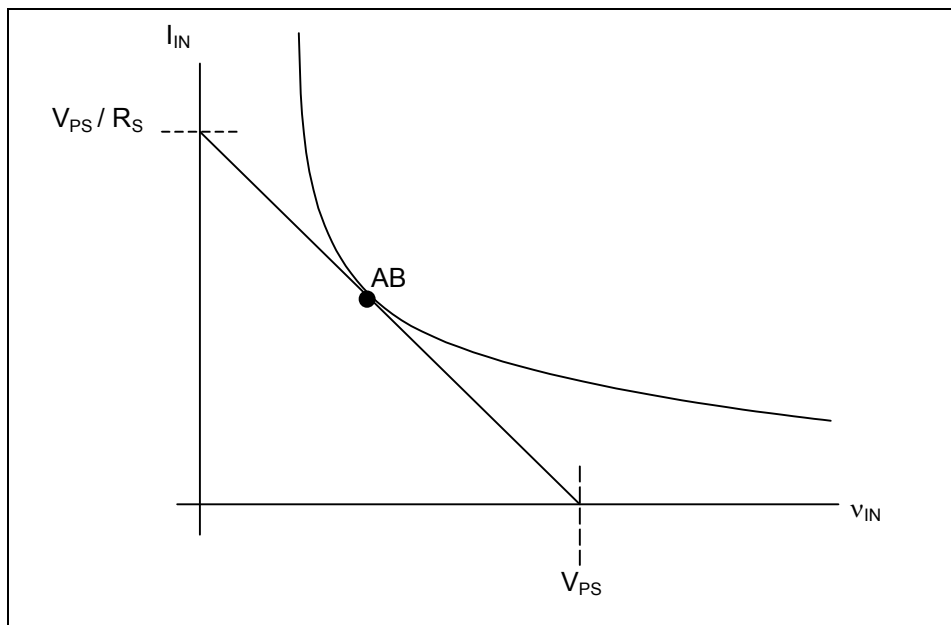

Figure 4 LOAD LINE LIMIT

DC-DC CONVERTER: REAL CHARACTERISTICS

Figure 5 shows the input characteristics of a real world DC-DC converter. As v_{IN} increases from zero, I_{IN} grows to a maximum (I_{MAX}) that occurs when V_{OUT} reaches its preset output voltage. The corresponding input voltage (V_{MIN}) is the minimum input voltage required for the DC-DC converter to produce its preset output voltage.

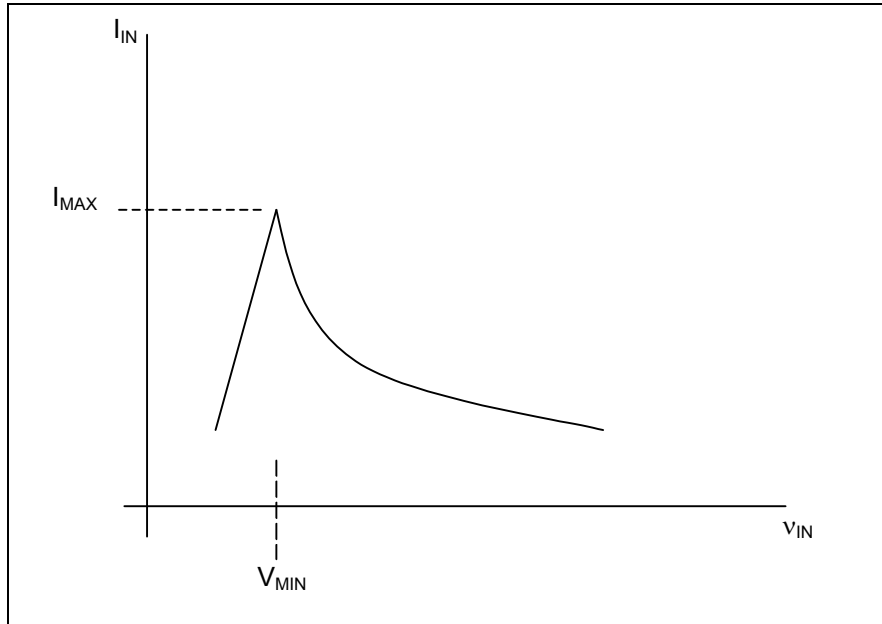

Figure 5 INPUT CHARACTERISTICS OF A REAL DC-DC CONVERTER

DESIGNING OUT BISTABILITY

We want to design out bistability and at the same time still be able to operate our equipment with the highest possible R_S (and thus longest cable length).

The normal way of avoiding bistability is to ensure that R_S is always smaller than the bistable resistance $R_{BISTABLE}$. This is done by arranging the load line so that it only crosses the DC-DC converters I-V at one place, as shown by load line (a) in Figure 6.

The equation for $R_{BISTABLE}$, derived from load line (a) [1] is given as:

$$R_{BISTABLE} = \frac{\eta_{DC} V_{MIN}(V_{PS} - V_{MIN})}{P_L} \quad (11)$$

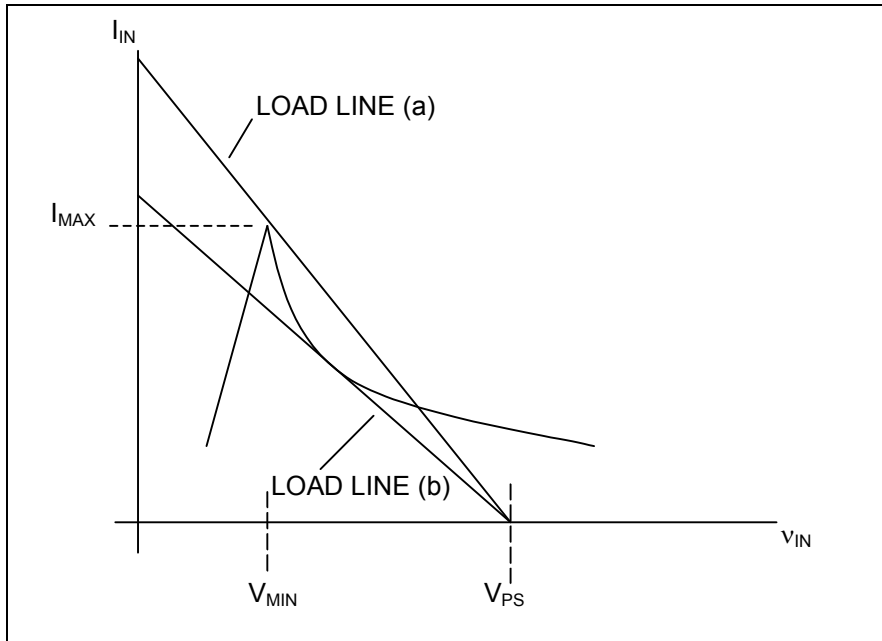

Figure 6 AVOIDING BISTABILITY

Using load line (a) means we have to accept a lower value R_S (and therefore a shorter cable length) when compared to a higher R_S (longer cable length) we could have for load line (b). However, load line (b) takes us into bistable operation. So what's the answer? Load line (b) is our optimal load line. The problem with it is during power-up (see Figure 7), if no action were taken, stable operation would be reached at state C, when in fact we want to operate at state AB.

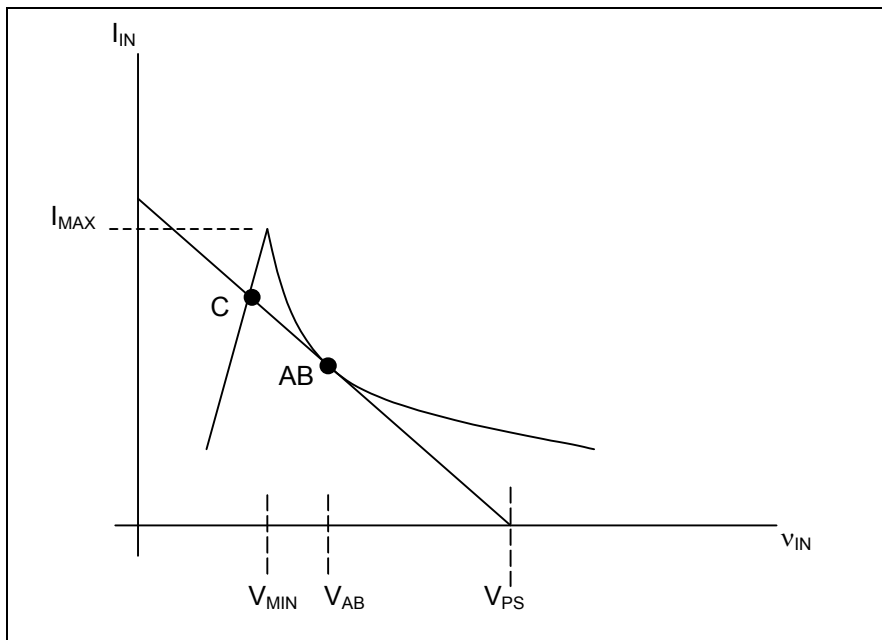

Figure 7 OPTIMAL LOAD LINE (WITH LOAD)

We can avoid this by switching out the load until v_{IN} reaches some voltage above V_{MIN} . This effectively lowers the DC-DC I-V curve so that load line (b) only has one crossing (see Figure 8). When stable operation is achieved in state A (Figure 8) the load is switched in, and as the DC-DC I-V curve rises, state A will move to AB in Figure 7. The effect of load switching can be more clearly seen in Figure 10.

The question that leaves us with, is: What v_{IN} do we use to switch in/out the load?

The answer is V_{AB} from equation (10) above.

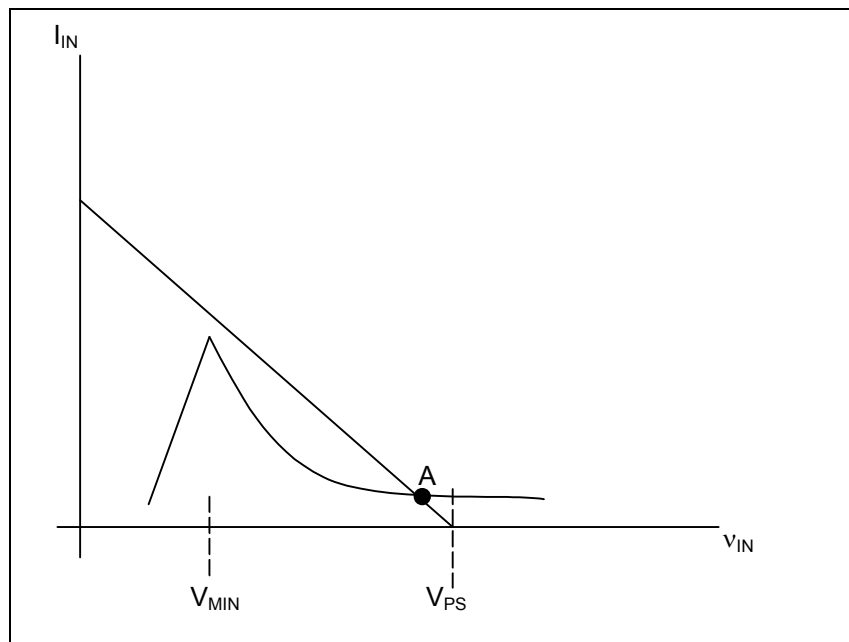

Figure 8 OPTIMAL LOAD LINE (NO LOAD)

So, why use V_{AB} and not some voltage just above V_{MIN} ? Suppose our equipment is located closer to the power supply using the same type of cabling. This will lower R_S and move the load line as show in Figure 9. Of course, if we chose a voltage just above v_{IN} (but below V_B) our DC-DC would power-up fine establishing operation in state A, but what if the DC-DC converter changed state due to a power disruption and began unwanted operation in state B? It would stay in that state until the power is cycled. If V_{AB} had been chosen instead, any attempt by the DC-DC to operate in state B would result in the load being switched out and re-establishing operation in state A.

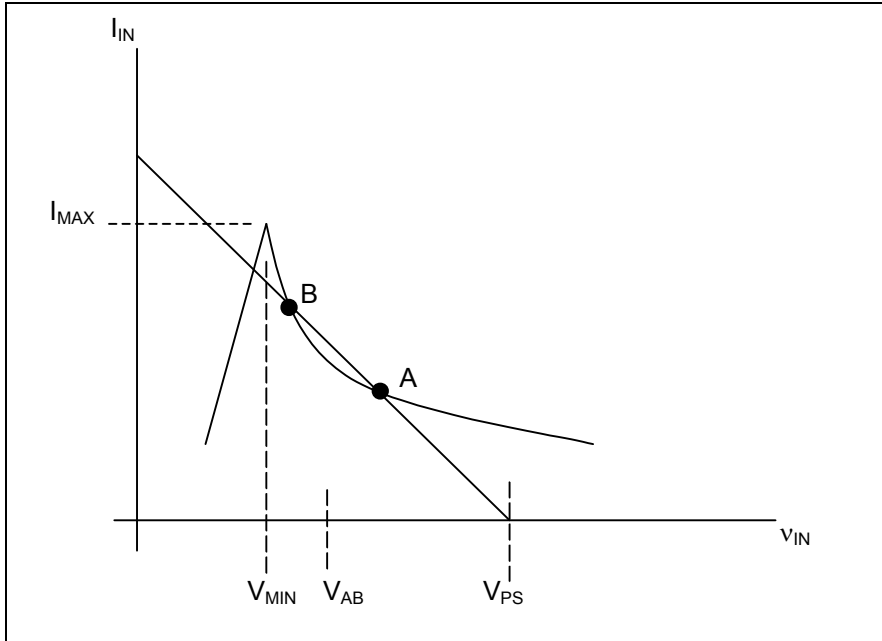

Figure 9 INTERMEDIAT LOAD LINE (WITH LOAD)

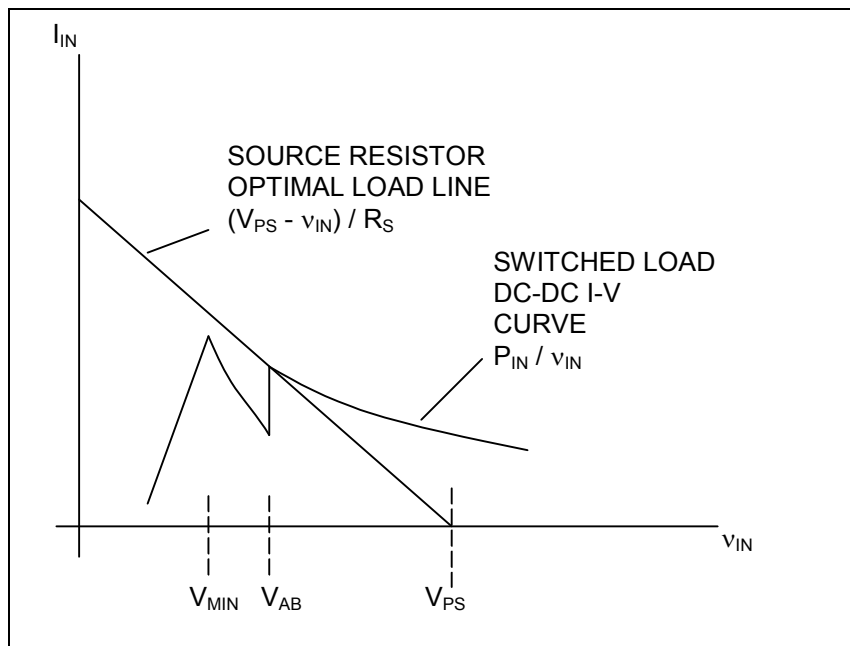

Figure 10 DC-DC I-V CHARACTERISTICS FOR LOAD SWITCHING

REVISED POWER SYSTEM

Let's now revise the power system to include a load switch (this could be a relay or a MOSFET) which is controlled by v_{IN} as shown in Figure 11. It's also desirable to insert an amount of capacitance C_{IN} to ensure smooth switching of the load. This capacitor should, in a hand waving way store enough energy to charge C_{OUT} to the chosen output voltage when the load is switched in.

Since energy in a capacitor is proportional to V^2

Then we can say:

$$C_{IN} = C_{OUT} \frac{V_{OUT}^2}{V_{IN}^2}$$

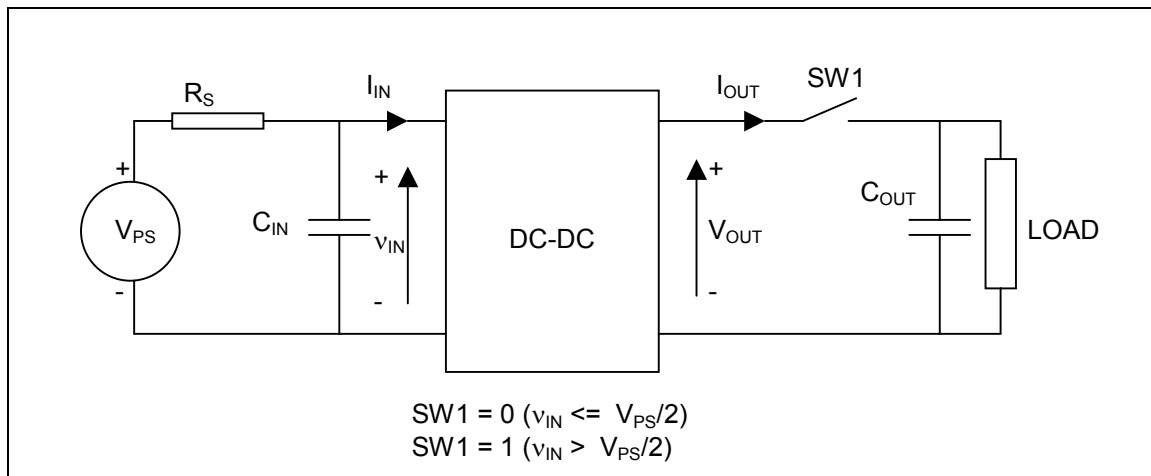

Figure 11 REVISED POWER SYSTEM

APPLICATION EXAMPLE

Example #1

Problem

What power-supply voltage (V_{PS}) and current (I_{IN}) is needed for an output power (P_{OUT}) of 3W given that the cabling has a loop resistance (R_S) of 40Ω and the efficiency of the DC-DC converter is 80%?

Solution

Assume we're operating with an optimal load line.

To find V_{PS} , rearrange (9) so that

$$V_{PS} = \sqrt{\frac{4 R_S P_{OUT}}{\eta_{DC}}} = \sqrt{\frac{4 \times 40 \times 3}{0.8}} = 24.49V$$

To find I_{IN} we need v_{IN} , which we take as V_{AB} (for an optimal load line) using (9)

$$V_{IN} = V_{AB} = \frac{V_{PS}}{2} = \frac{24.49}{2} = 12.24V$$

V_{AB} is also the load switching voltage.

from (4)

$$I_{IN} = \frac{V_{PS} - V_{IN}}{R_S} = \frac{24.49 - 12.24}{40} = 0.306A$$

Example #2

Problem

Will a power supply rated at 48V / 0.1A be suitable for a load power (P_{OUT}) of 3W given that the cabling has a loop resistance (R_S) of 40 Ω and the efficiency of the DC-DC converter is 80%?

Solution

This leads on from example #1, as a 48V / 0.1A supply might be the only one available to you.

We know V_{PS} of 48V is OK as it's higher than 24.49V (assuming the DC-DC can accept this voltage), all we have to find is the current (I_{IN}) required from the supply. Now that V_{PS} is higher, the load line will be shifted to an intermediate position similar to the one in Figure 9.

To find I_{IN} we need v_{IN} , which we take as V_{INA} (for an intermediate load line) using (7)

$$V_{INA} = \frac{V_{PS} + \sqrt{V_{PS}^2 - \frac{4 R_S P_{OUT}}{\eta_{DC}}}}{2} = \frac{48 + \sqrt{48^2 - \frac{4 \times 40 \times 3}{0.8}}}{2} = 44.64V$$

from (4)

$$I_{IN} = \frac{V_{PS} - v_{IN}}{R_S} = \frac{48 - 44.64}{40} = 0.084A$$

This current (0.084A) can be delivered by the power supply as it is rated at 0.1A. Therefore the answer is yes; the power supply is suitable for this application.

As an added bonus, the 48V supply only has to deliver around four watts of power compared to the seven or so watts in example #1. Meaning our 48V supply will be both smaller and cheaper!

OBSERVATIONS

We should be aware that in practice operating with the optimal load line would most likely result in intermittent operation. It'd therefore be better to make a conservative approach and allow for an amount of variation in R_S , V_{PS} and P_{OUT} for worst case operating conditions before applying any formulae.

No mention has been made here of the power supply source resistance, this has the same affect as R_S and if significant needs including in the calculations (i.e. added to R_S).

REFERENCES

1. "Source Resistance: The Efficiency Killer in DC-DC Converter Circuits". Maxim Application Note 3166 (http://www.maxim-ic.com/appnotes.cfm/appnote_number/3166)

Disclaimer:

Although every care has been taken to ensure the accuracy of the information in this article, such information is provided "as-is" and without any warranty or implied fitness for any purpose. In acting on any information provided by this article you accept that this is entirely at your own risk and indemnify the author against any loss or damages, actual or consequential that may occur.